



(Antes I.E. Las Golondrinas)
Aprobado por la Secretaría de Educación del Municipio de Medellín
Según Resolución 09994 de 2007 DANE: 105001025771 NIT: 811040137-3

“Formamos ciudadanos integrales que dejan huella en el universo”

ASIGNATURA: Artística	Período: 3	Año 2023
DOCENTE: Diego Fernando Celis Blandon	Grado / Grupo:	Fecha:
ESTUDIANTE:		

PLAN DE MEJORAMIENTO TERCER PERIODO SÉPTIMO

Sustentación:

1. Presentar los 5 pasos del mapale, vistos durante las clases.
2. A partir de estos pasos, crear y mostrar una coreografía de 4 figuras, dónde halla:
 - a. Una entrada.
 - b. 2 Figuras de desplazamiento.
 - c. 1 Se vea una figura geométrica.

Trabajo escrito:

3. En hojas blancas tamaño carta deben presentar la planimetría, de la coreografía que crearon para la sustentación. Cada figura de la coreografía debe tener el nombre de la figura que se interpreta en la danza.
4. Presentar la máscara del zorro totalmente terminada y decorada.

Criterios de evaluación:

- El trabajo escrito se debe entregar completo. No se recibe por partes.
- Todos los dibujos deben ser hechos a mano y deben estar pintados.
- Las consultas deben estar en hojas blancas u hojas cuadrículadas de block tamaño carta. No se recibe en el cuaderno.
- Si la información consultada no corresponde a lo pedido en el plan de mejoramiento, no se recibirá el trabajo.
- La sustentación debe ser individual o en pareja.
- Debe presentar todos los puntos de la sustentación.



WINTERCROFT

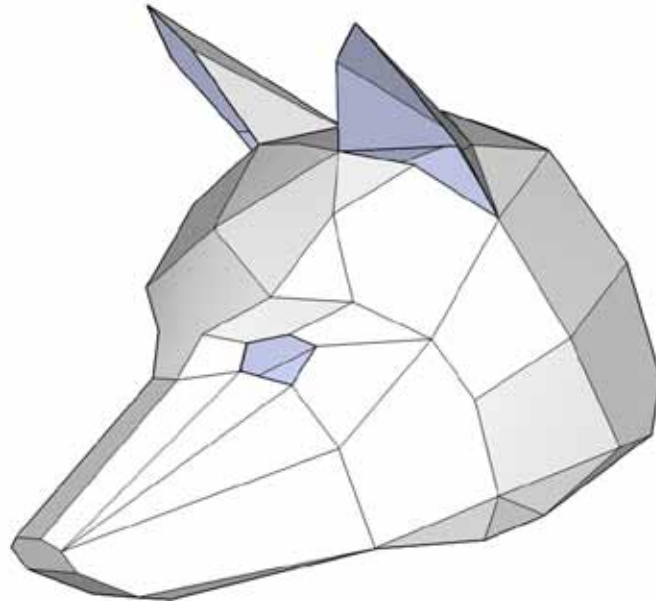

Fox Mask

Designed by Steve Wintercrot

This mask can be built by simply taping the edges together or by using the tabs to glue the edges together.

Choose

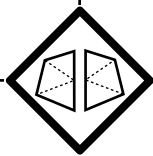

Untabbed Construction

Choose this construction technique if you are short of time, or are looking for a quick and easy project. Building this mask without tabs is much quicker and although the finished mask will still look awesome it will not be as neat.

Build time approx: 2 hours

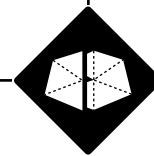

Tabbed Construction

Choose this construction technique if you have plenty of time, are looking for a more substantial project and want to achieve the best possible finish. Building this mask using tabs will take longer but the finished mask is stronger and will look neater.

Building time approx: 4 hours



WINTERCROFT

Materials Required

- Access to a printer and 20 sheets of A4 paper or US Letter paper.
- Thin card, the type used in cereal boxes is ideal. Thicker card, such as corrugated card, does not work well as it will not bend to the detailed folds. The approximate area required is around 7 sheets of flat A3 card.
- Spray mount, Pritt Stick, PVA or similar product that will stick paper to card.
- Scissors and a craft knife.



For Untabbed Construction

- Straight forward sticky tape, you can use basic cheap tape but I've found that Scotch Magic invisible tape gives a neater finish.



For Tabbed Construction

- A fast setting adhesive for gluing the tabs and assembling the mask. You want to use a glue with a fast curing time so that you don't have to wait for parts to dry before continuing. PVA glue works ok but I use a glue stick (Pritt Stick) as this is quick, clean and convenient. A high quality double sided tape is also a good alternative. As you will be putting the mask on your head don't use a solvent based glue that could give off harmful fumes.

Printing Advice

- The templates are 1:1 scale and are intended to be printed at ACTUAL SIZE on either A4 paper (210mm X 297mm) or US Letter paper (8½" X 11"). In your printer setting please select the type of paper that you are printing on but **DO NOT SCALE THE TEMPLATES TO FIT THE PAPER.**
- I have included a Scale Guideline on the first page of the templates so that you can check the scale. The line should measure 150mm after printing but plus or minus 2mm is acceptable. There is more information on printing the templates in our FAQ section of the website.
- **Please check that your print out contains all of the fold lines that are shown on the PDF.** If not please update your PDF reader to the latest version of Adobe Reader (free) and reprint. This will correct the problem.

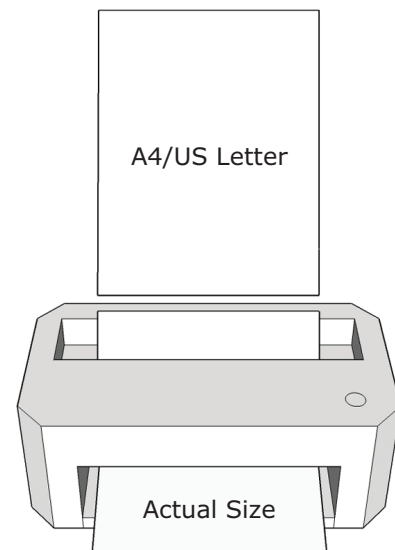



WINTERCROFT

1. Having printed the templates on paper, trim them roughly to the approximate size, they don't have to be neat. Trimming off the excess paper makes it easier to arrange the templates on the card.
2. If you are working with reclaimed card unfold your boxes so that you have flat sheets to work with, then glue the templates to the card. When you assemble your mask, your templates will be on the inside faces of the mask. A good quality glue stick is cheap and works well for this. Make sure that the templates are well bonded to the card.

3. Cutting

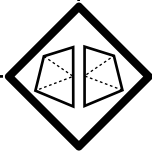

Untabbed Cutting

Cut around the outside of each part. As you will be taping the edges together, you will not need the grey tabs so they can be cut off at this point. The direction of the fold line on the tabs are not important as these are the edges that you will be taping together.

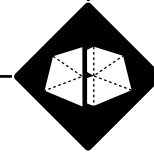

Tabbed Cutting

As you will be using the grey tabs to assemble the mask make sure to only cut along the solid outlines.

4. The fold lines on the templates are marked as either a dashed line representing a valley fold or dashes with dots to represent a mountain fold. This is with the templates on the inside of the mask.
5. Score all of the folds marked on templates with something blunt like an old ball point pen. Scoring weakens the card along the fold lines and helps to keep your folds neat. Score and fold all of your parts.

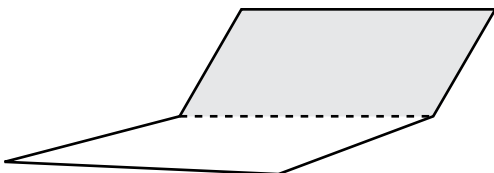

Dashed line represents a valley fold



Dashed line with dots represents a mountain fold



WINTERCROFT

5. Starting with the parts labelled (A) and (B) find two edges with corresponding numbers.

For example edge number 14 joins to edge number 14. The numbers do not need to be completed sequentially. Then follow either the tabbed or untabbed instructions below.

Assembly

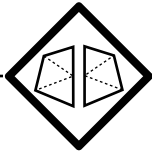

Untabbed Construction

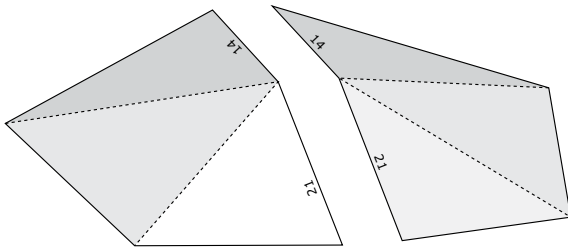

Having found two edges with matching numbers, hold the edges together and apply tape along the join. Taping on the outside makes things easier for most parts but if you come to a part that is difficult to tape outside, try taping inside the mask. If a join feels like it is under stress, tape it inside and out to reinforce it.

Tape one edge at a time, test fitting each part before applying the tape. I've labelled the first few parts to get you started, from there continue matching the corresponding numbers to complete the mask.

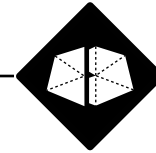

Tabbed Construction

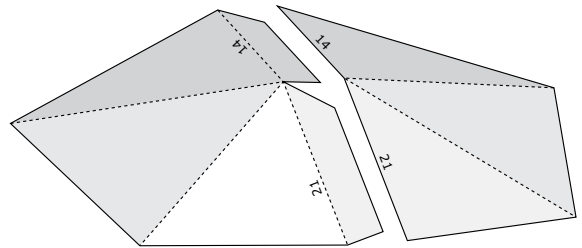

In each pair of numbered edges one part will have a gluing tab and one will not. The gluing tab will always go on the inside of the mask.

Test fit the part before you apply glue to the tab. I recommend using a glue stick or double sided tape. Once you are happy with how the parts fit together, apply glue to the outer surface of the tab and bring the two edges together remembering that the tab goes inside the mask.

Apply pressure to the join until the glue has set enough to hold on its own. Glue one tab at a time, test fitting each part before applying the glue. I've labelled the first few parts to get you started, from there continue matching the corresponding numbers to complete the mask.



WINTERCROFT

Once you have built the mask, make the head band following the instructions on the final page and tape it to the inside of the mask.

You can paint or decorate your mask in any way that you like. Have a look at our website or Facebook page for inspiration.

Tag your photos with the hashtag **#wintercraft** to share them with our community.

If you run in to any problems or have any questions please check the frequently asked questions on:

www.wintercraft.com

If you still can't find the answer to your questions, then please send me a message to the address in the contacts below.

Please Note

These designs are protected by copyright law and are intended for your own personal use only. Please use this file to make as many masks as you like for yourself but please don't share or steal the templates, there was a lot of work involved in creating them. If you want to use them for any other reason then please get in touch. Selling items made from our templates is prohibited.

THESE MASKS ARE A PERSONAL CRAFT PROJECT, PLEASE DO NOT USE THEM FOR PROFIT.

Contact Us

I would love to see your finished creations, please share them on our Facebook page:

www.facebook.com/wintercraftmasks

or use the hashtag **#wintercraft** or Instagram handle **@wintercraft**

Many thanks and have fun,



Steve

info@wintercraft.com



Scale Guideline

To check the scale is correct, the line below should be 150mm from end to end.

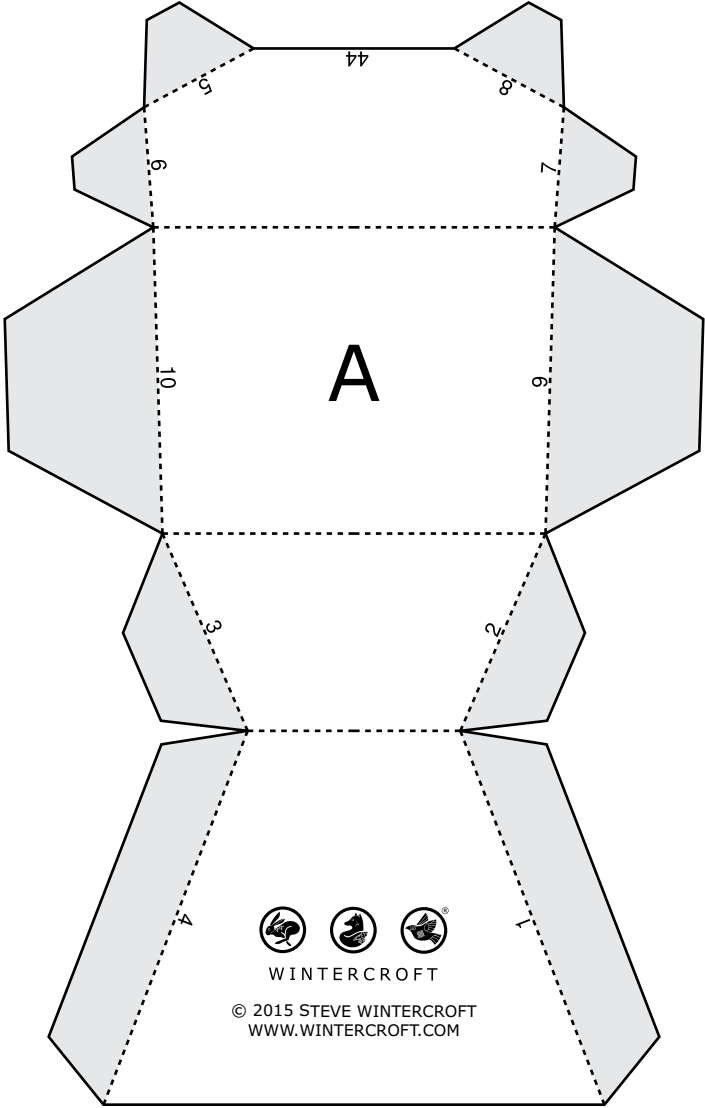

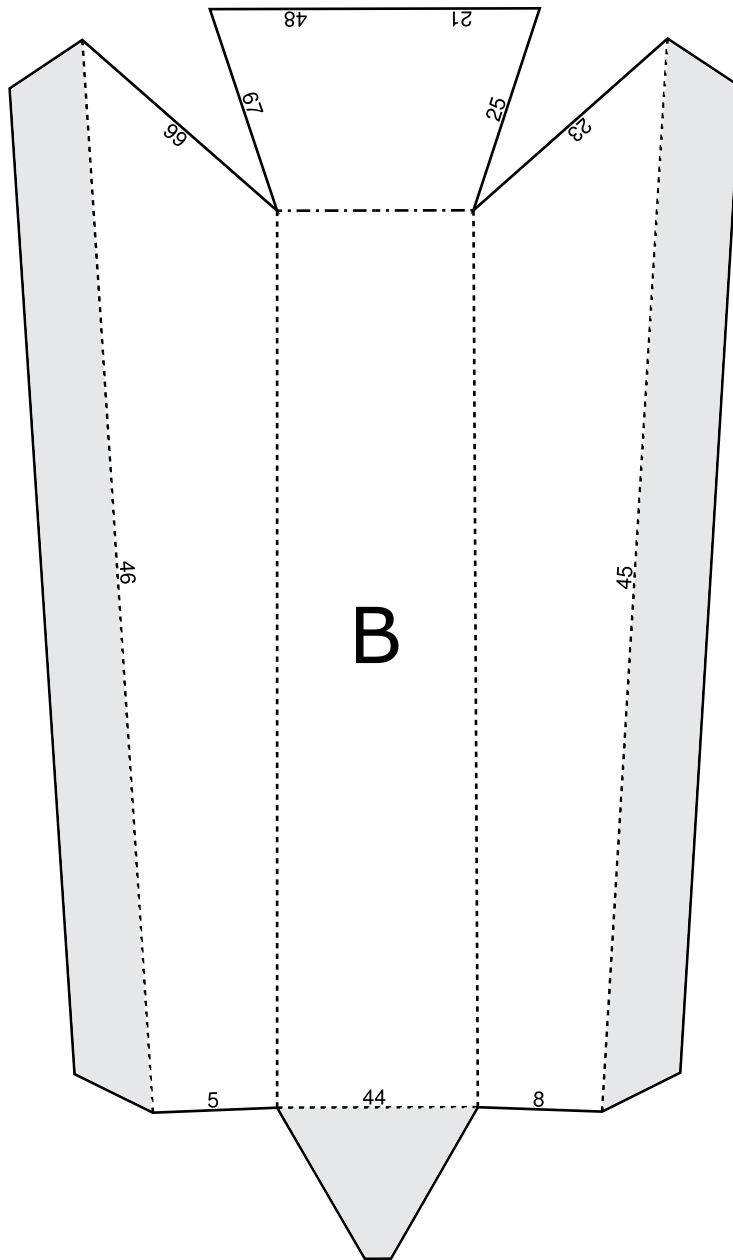

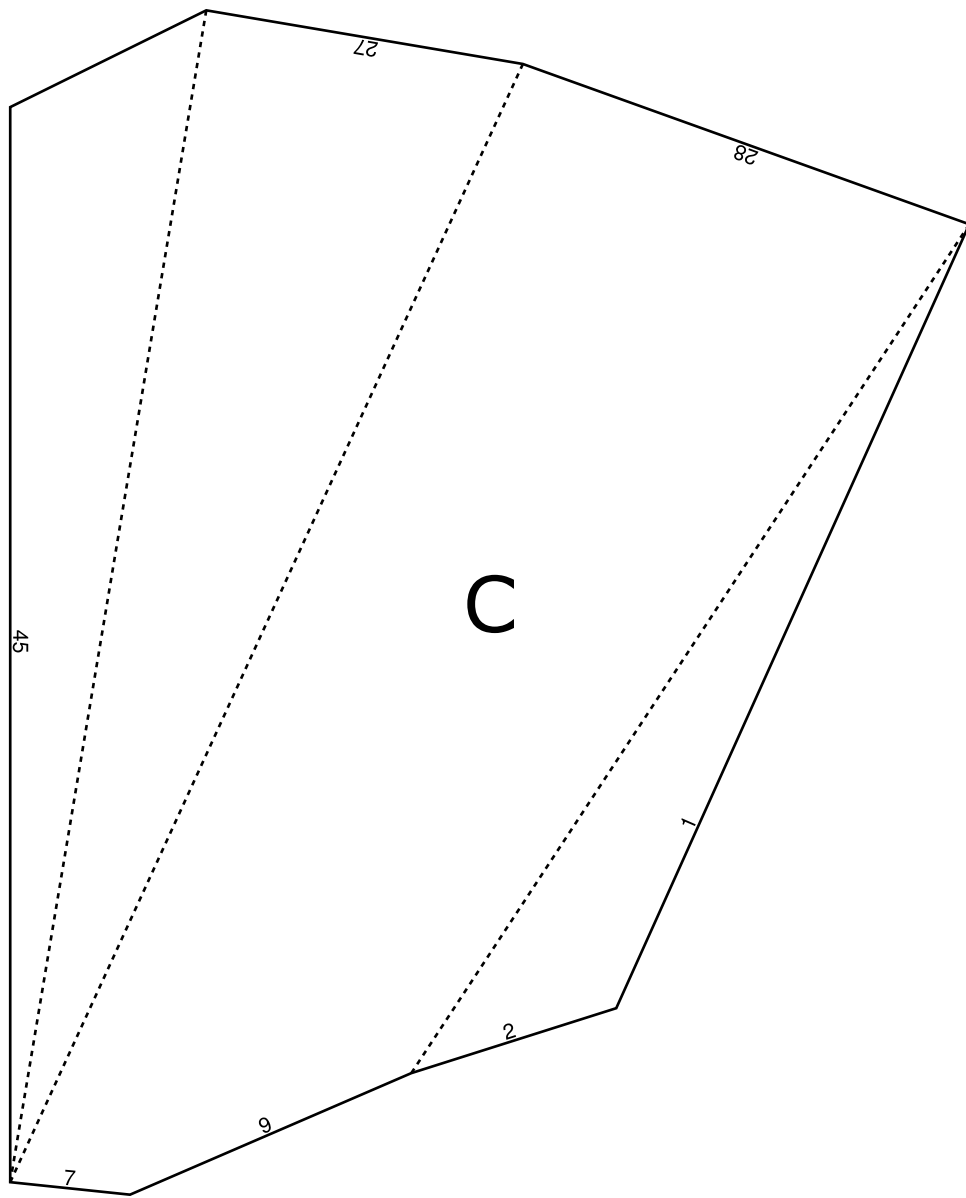

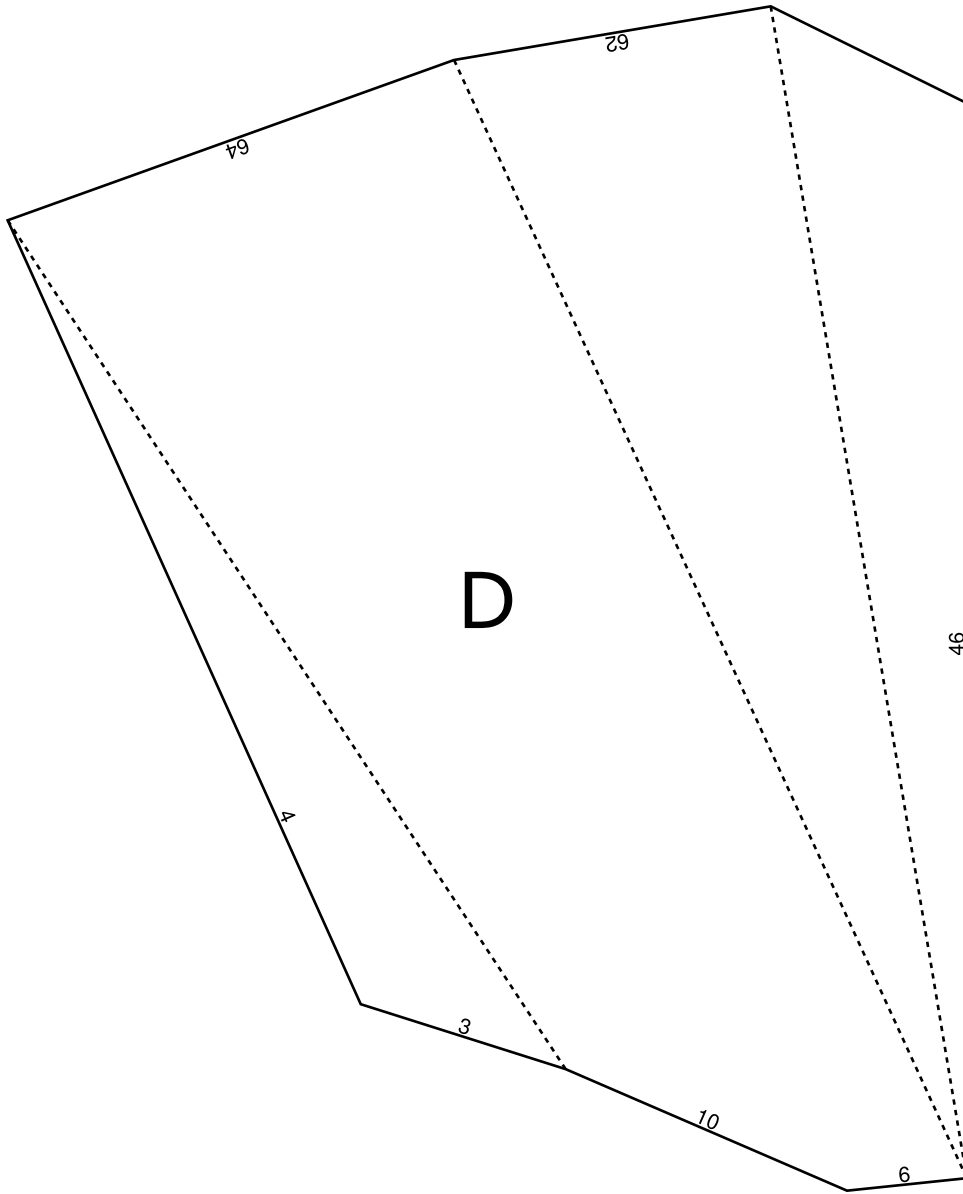

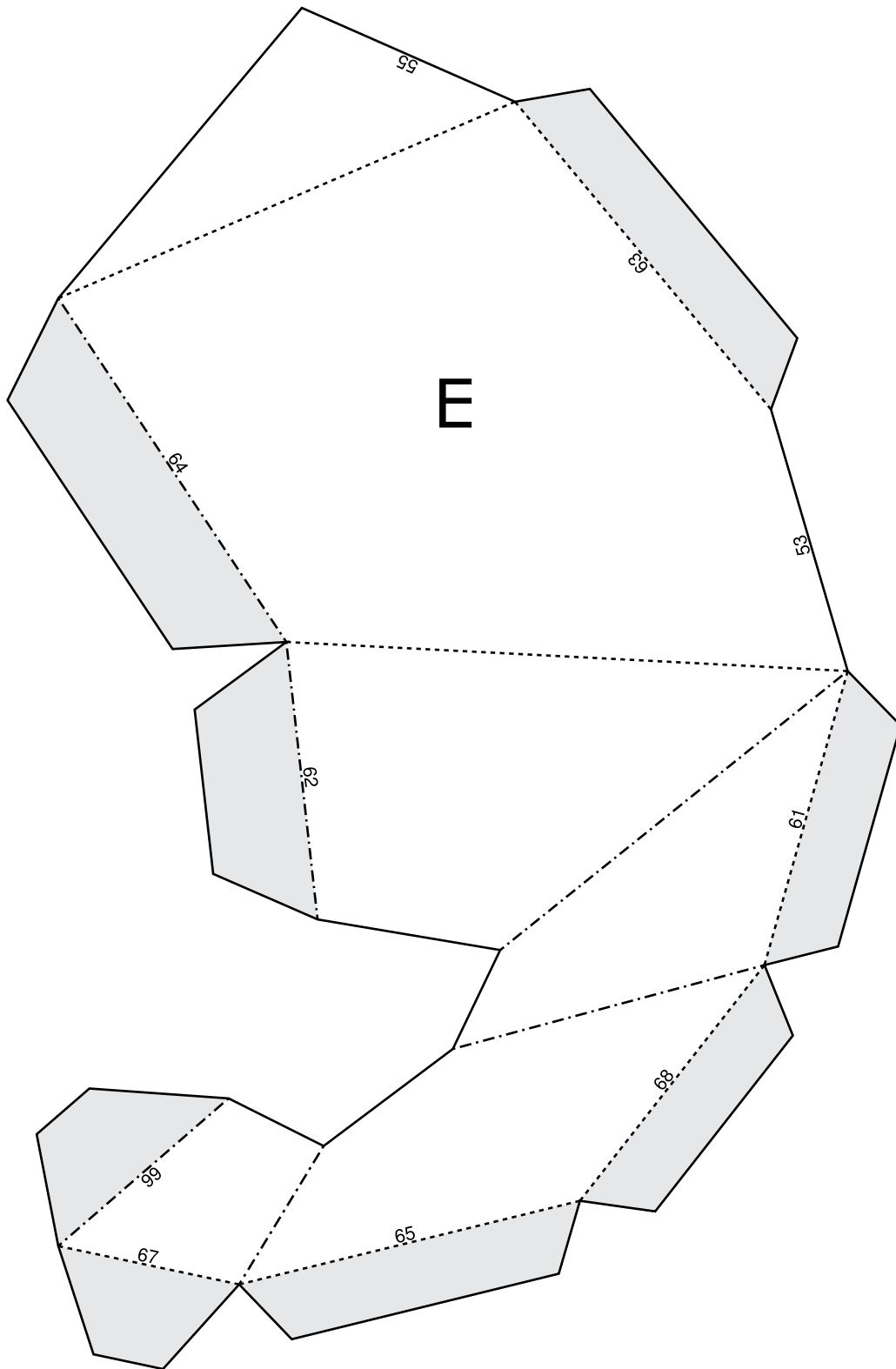

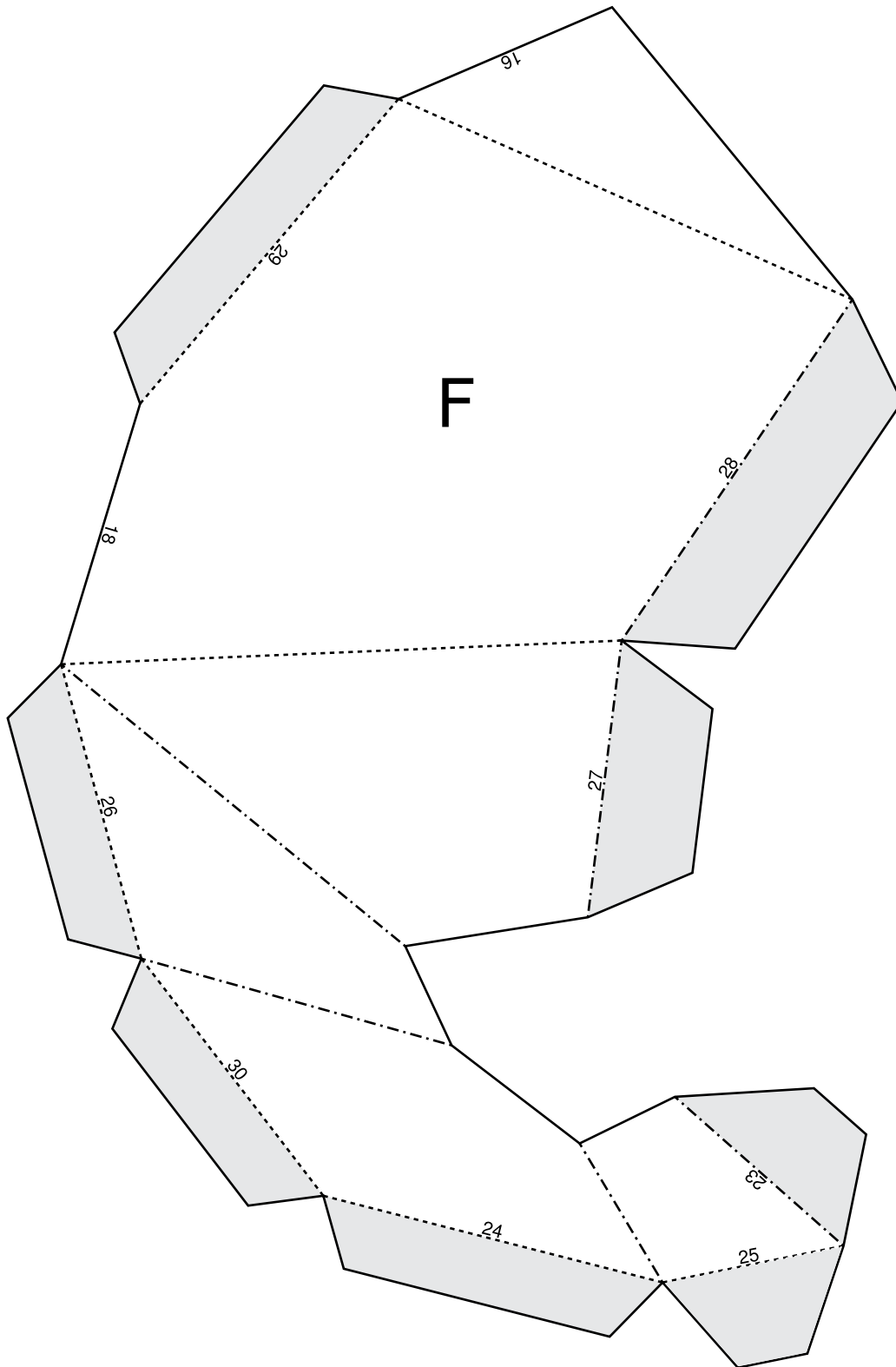

F

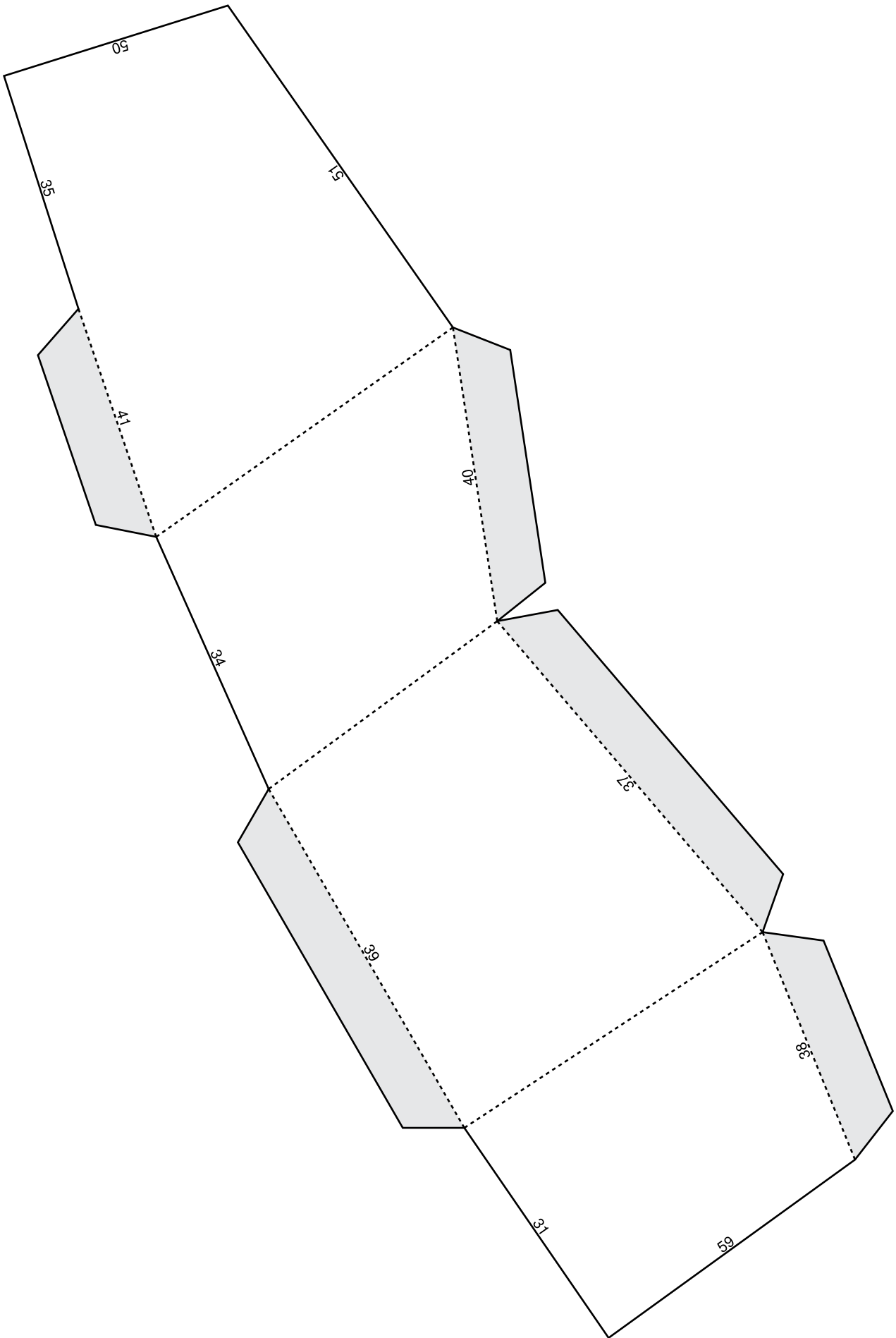

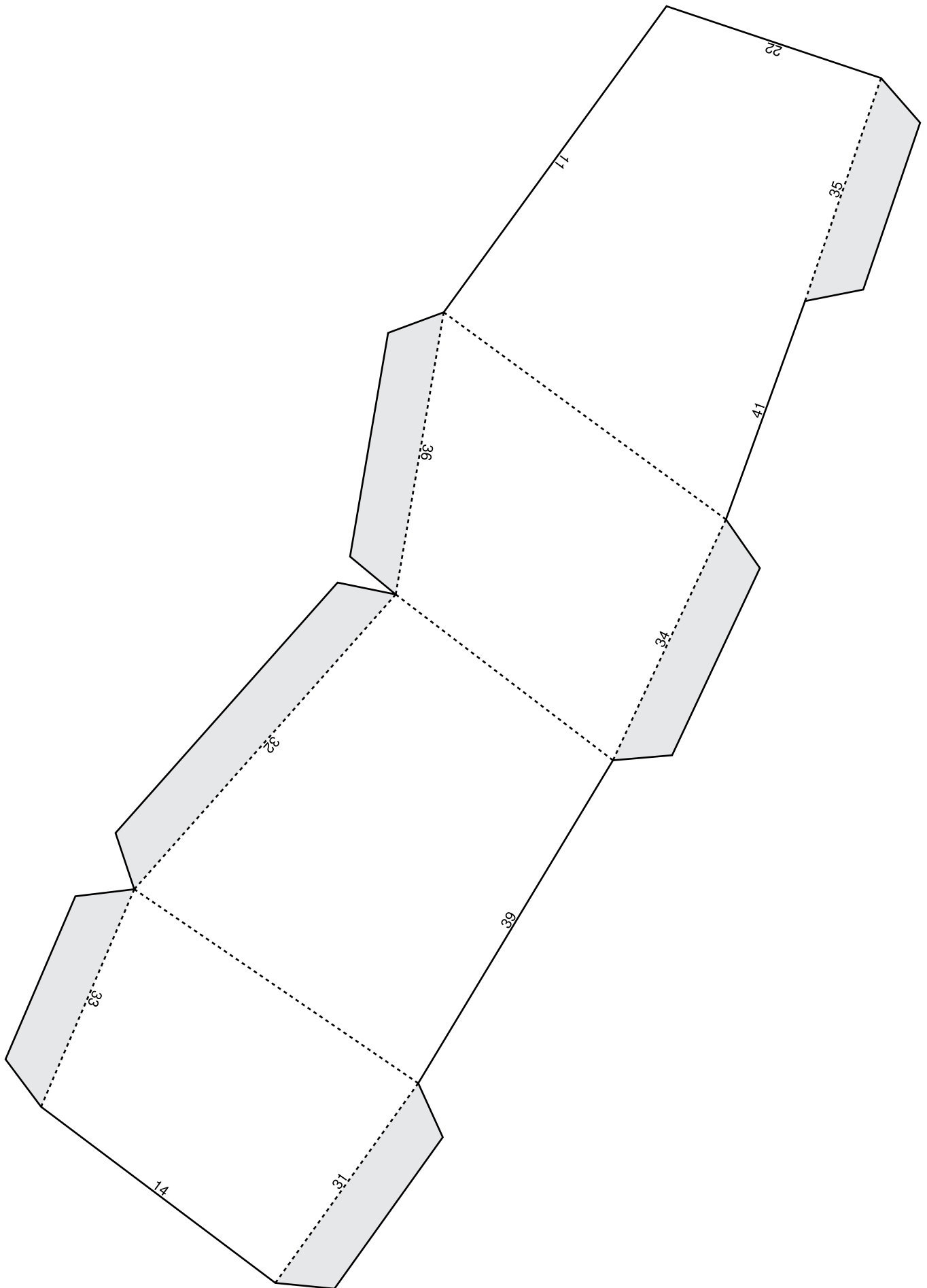

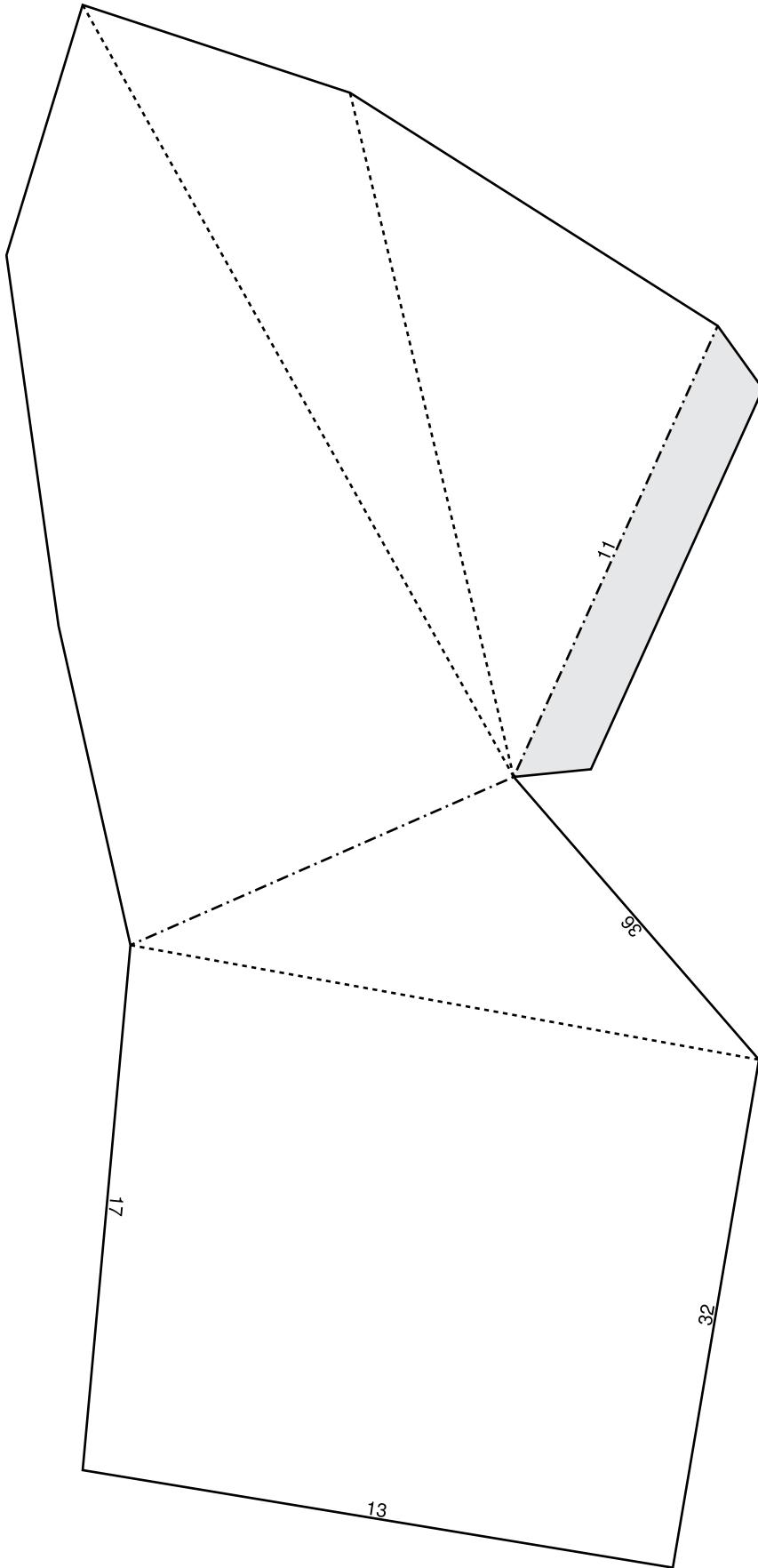

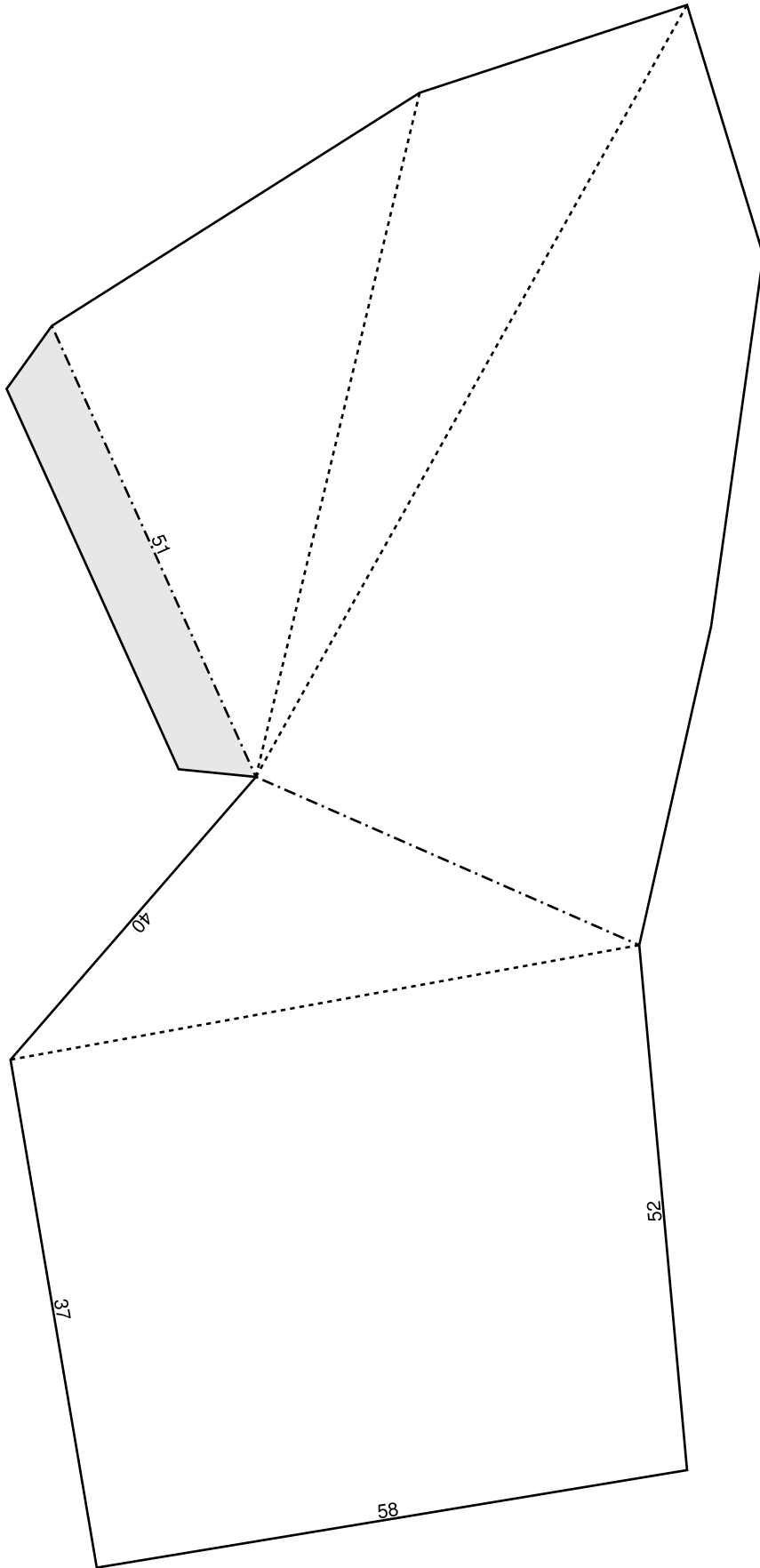

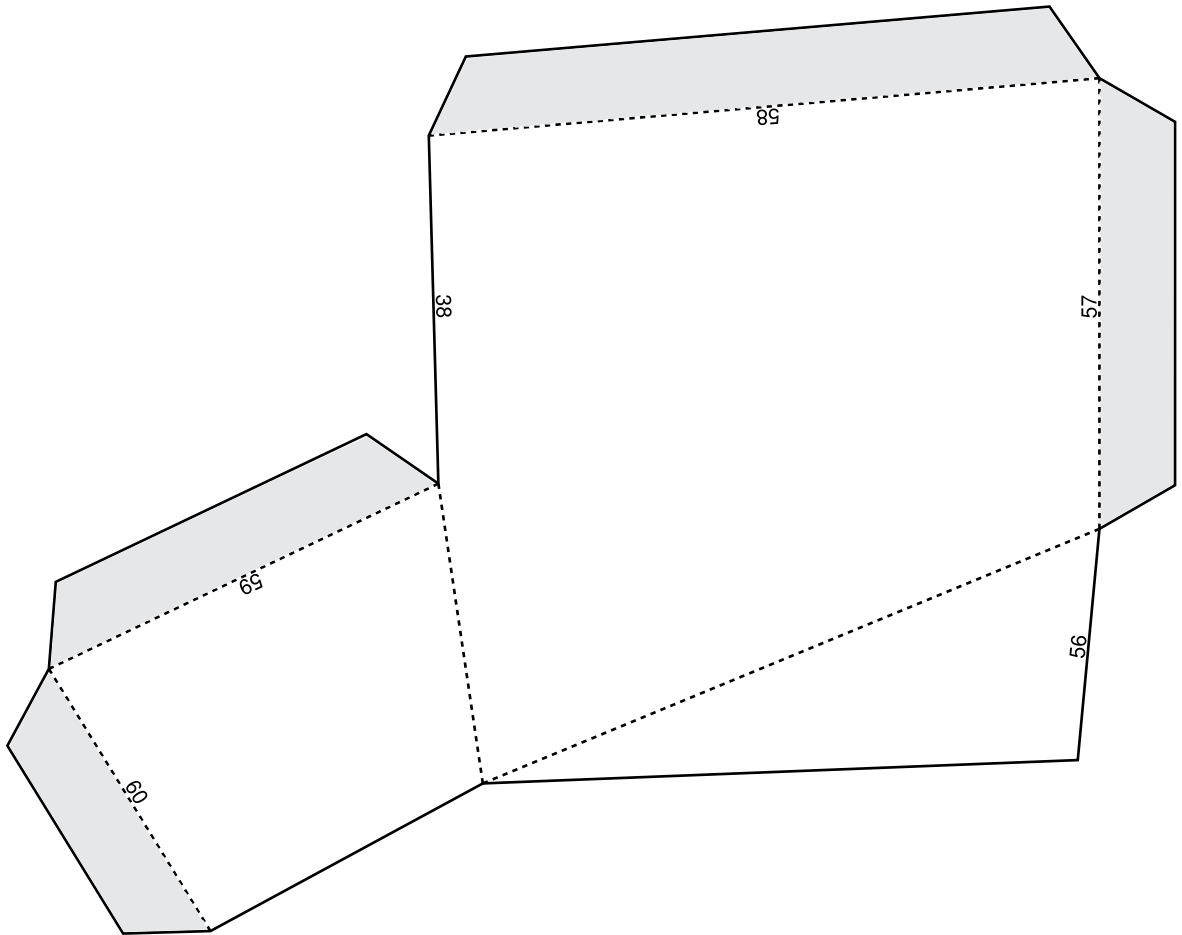
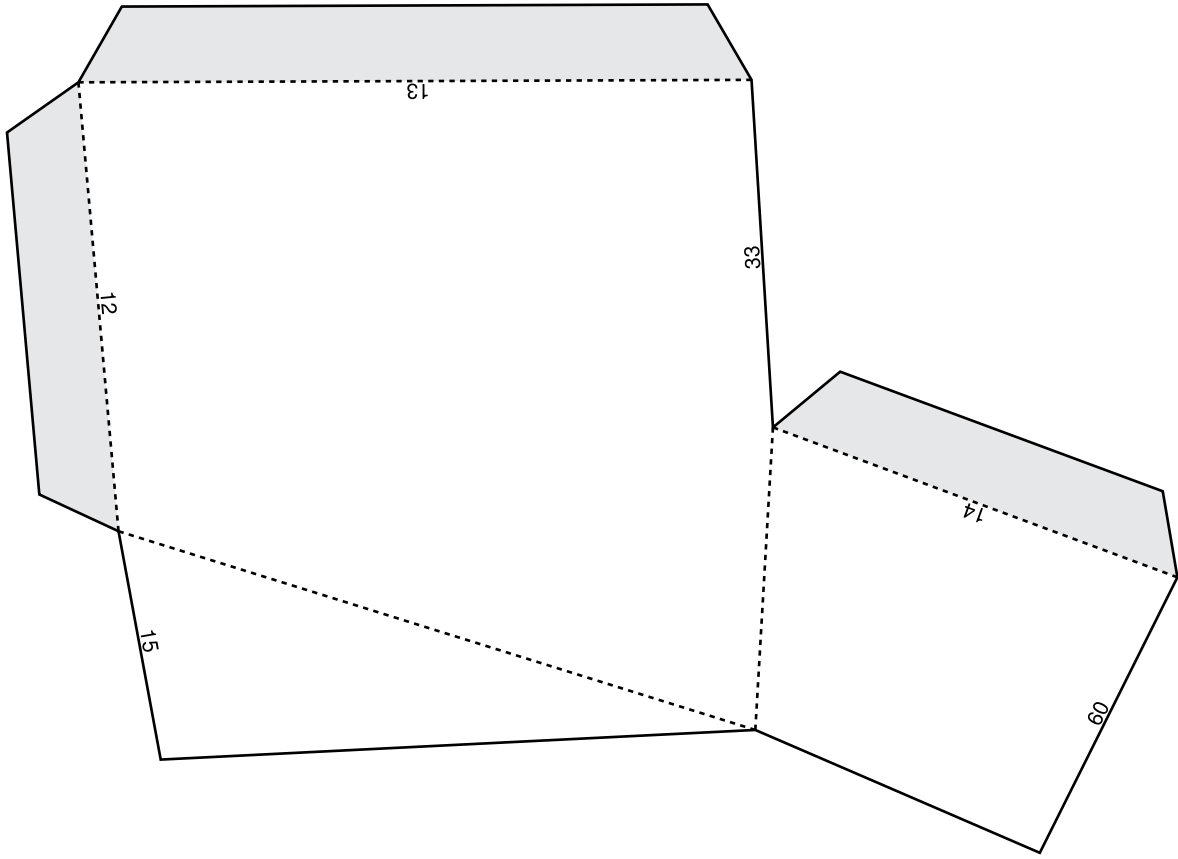

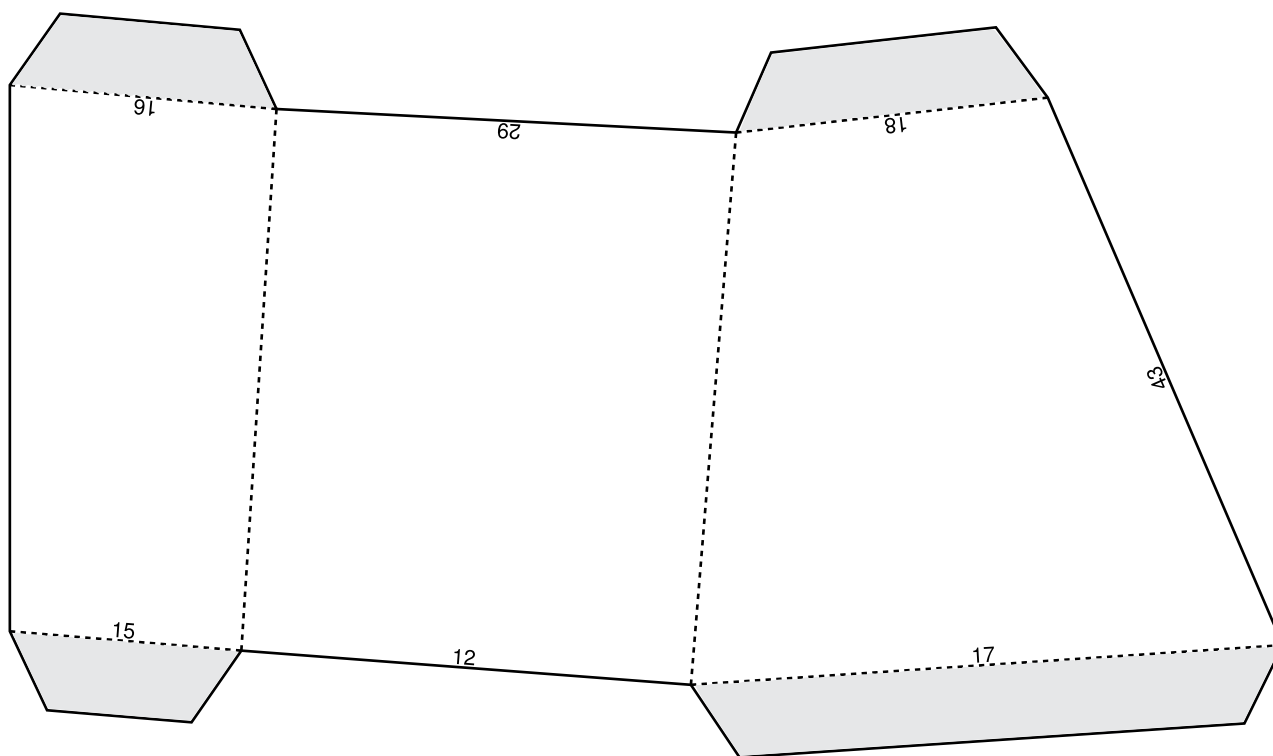
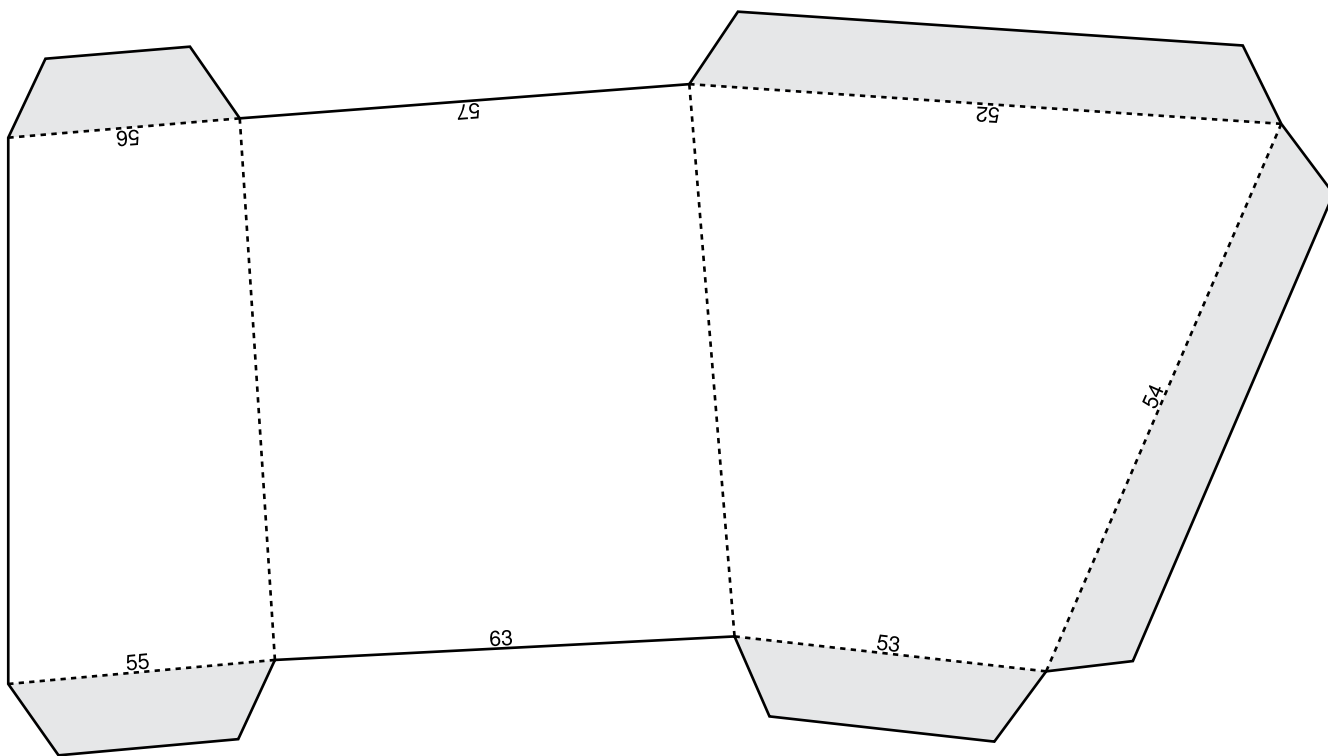

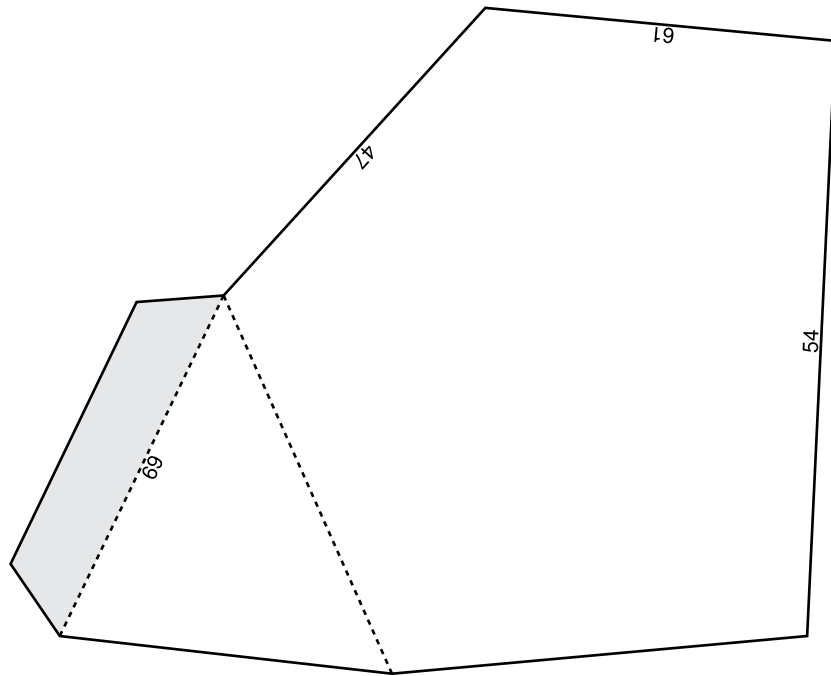
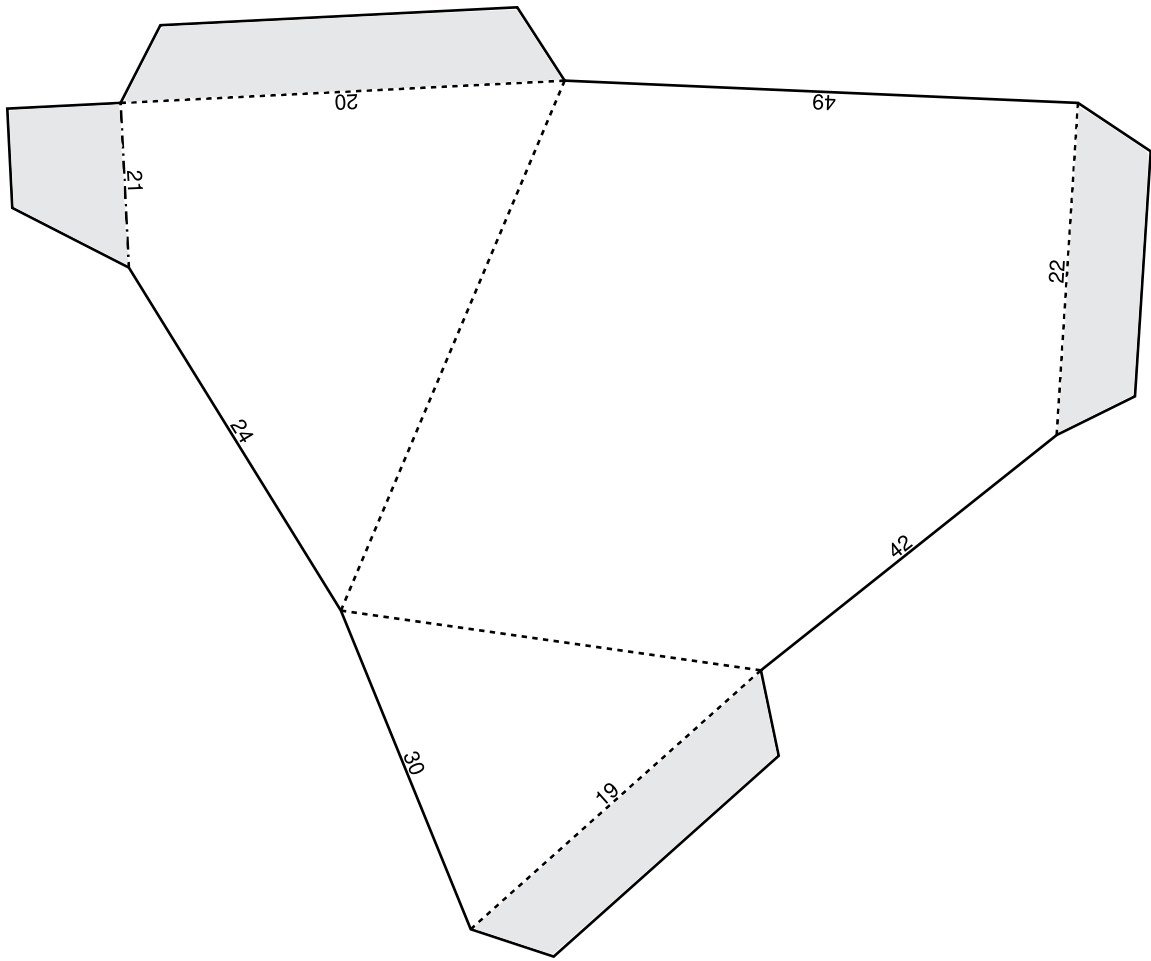

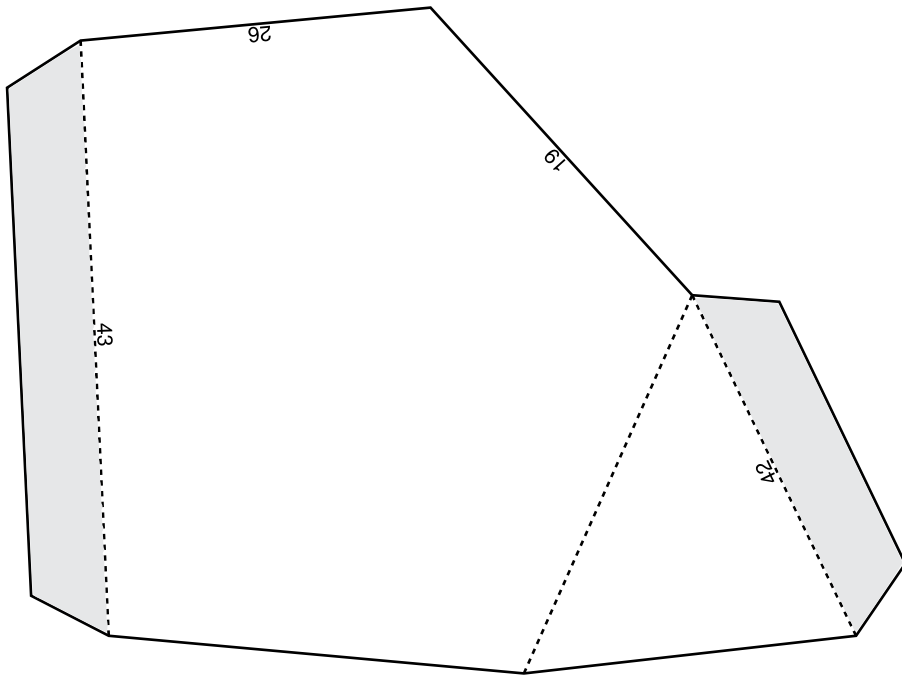
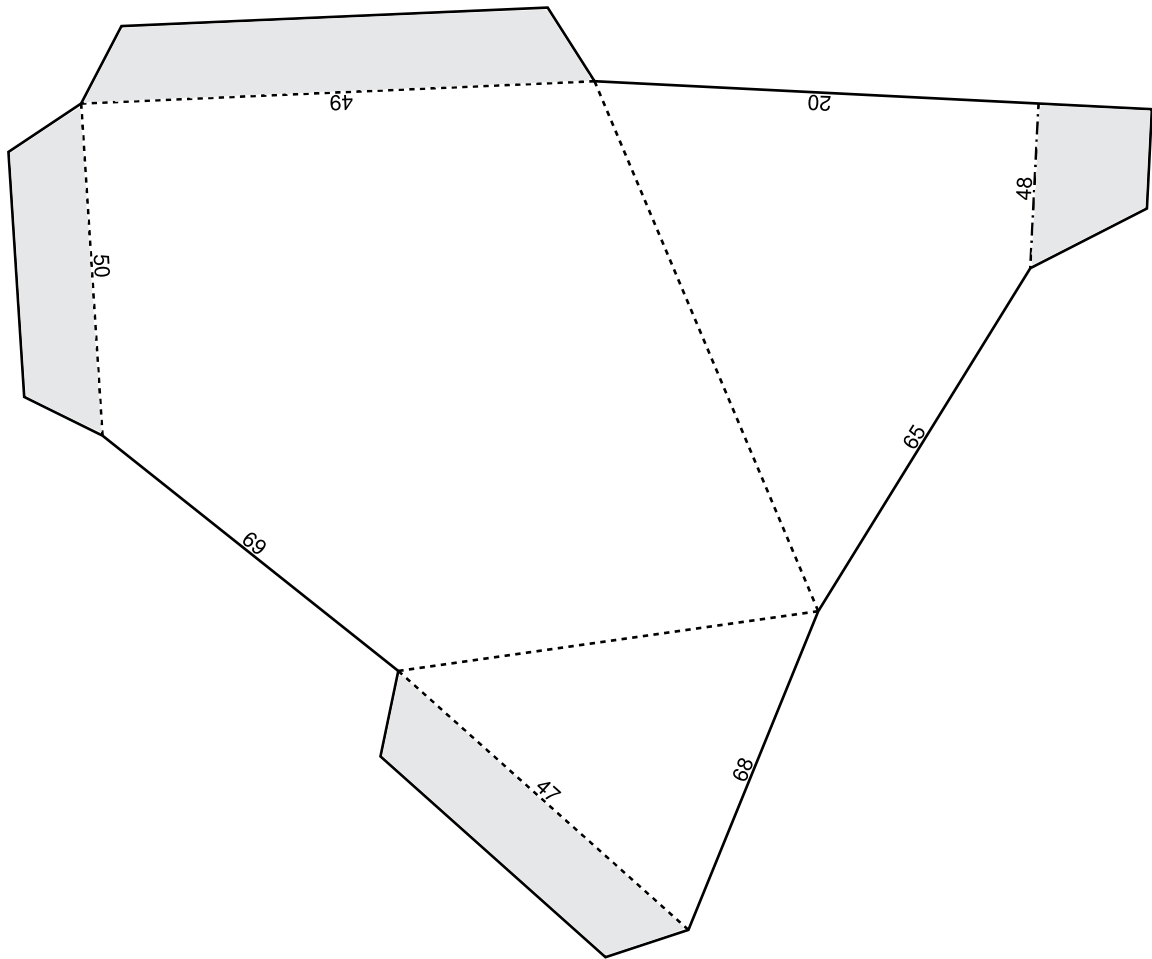



WINTERCROFT

Head Band

To ensure the completed mask fits well you can make a head band and fit it inside of the mask.

Assembly Instructions

1. Cut three strips of card to roughly the dimensions below and join the ends together to form one long strip. We have allowed 50mm overlap for each join.
2. Wrap the band around your head overlapping the open ends and tape together to get a good fit. The band should be snug but not tight.
3. Take the band off your head and tape the front of the band to the front of the inside of the mask. Make sure that the vertical tabs are pointing towards the top of the mask.
4. Tape vertical tabs to the inside of the mask to secure the band in place. You might need to move the tabs around a little until you get it fitting right.

NOT TO SCALE

Cut three pieces of card at these dimensions

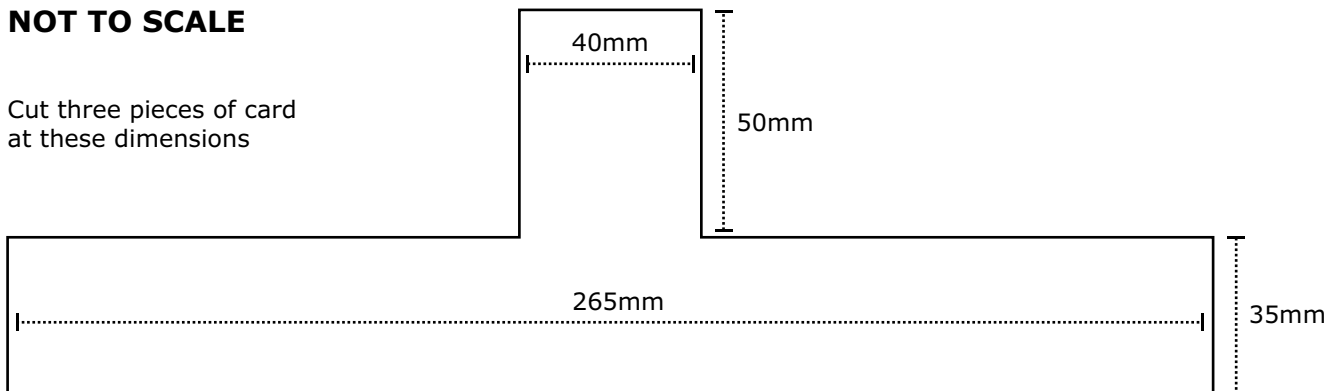

Tape together here with 50mm overlap

Tape together here with 50mm overlap

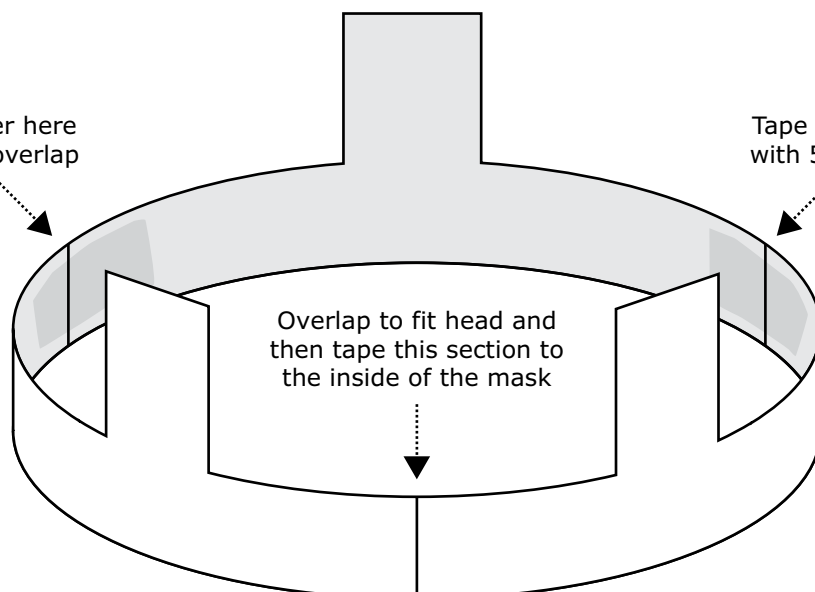

Overlap to fit head and then tape this section to the inside of the mask